

OPERATING INSTRUCTIONS



Intended to alert the user to the presence of uninsulated "dangerous voltage" within the product's enclosure that may be of sufficient magnitude to constitute a risk of electric shock to persons.



Intended to alert the user to the presence of important operating and maintenance (servicing) instructions in the literature accompanying the product.

CAUTION: Risks of electrical shock — DO NOT OPEN

CAUTION: To reduce the risk of electric shock, do not remove cover. No user serviceable parts inside. Refer Servicing to qualified service personnel.

IPATM 300T

High Performance

Utility Amplifier



PEAVEY[®]

ARCHITECTURAL
ACOUSTICS[®]



WARNING!

DO NOT ATTEMPT TO INSTALL THIS UNIT WHILE IT, OR ANY CONNECTING UNITS, ARE POWERED ON. RISK OF ELECTRICAL SHOCK EXISTS IF ALL UNITS ARE NOT POWERED OFF DURING INSTALLATION. TO PREVENT ELECTRICAL SHOCK OR FIRE HAZARD, DO NOT EXPOSE THIS APPLIANCE TO RAIN OR MOISTURE.

DESCRIPTION:

The IPA™ 300T is a high performance power amplifier designed to meet the needs of the most demanding fixed installation/PA application. The convenient patch panel layout, coupled with state of the art circuit design assures reliable long-term operation and smooth trouble-free installation.

Twenty five and seventy volt fully isolated line output capability is standard equipment. The IPA 300T has been packaged for standard 19" "rack-mount" capability and occupies 5¼ inches of vertical rack space.

FEATURES

POWER OUTPUT:

- 300 Watts RMS into 4 ohms

CONTROLS AND INDICATORS:

- Level control
- Subsonic filter switch
- SPS Switch
- Power on LED
- Power switch

OUTPUTS:

- 4 ohm screw terminal direct output
- 8 ohm balanced output
- 70 volt balanced output
- 25 volt balanced output
- 1V/600 ohm balanced output
- AC convenience outlet

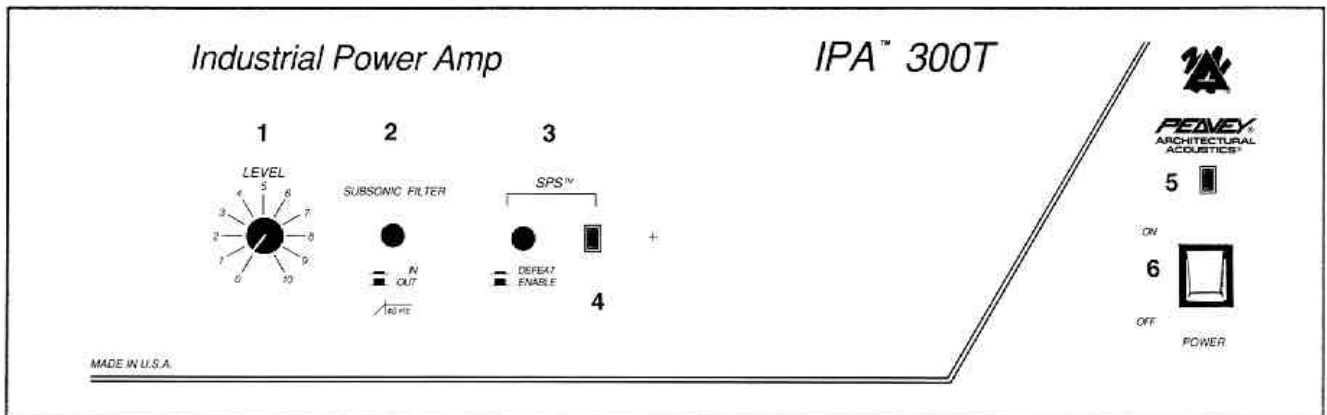

LEVEL (1)

Controls the volume level of the system.

SUBSONIC FILTER (2)

The "in" position of this switch activates the 18 dB/octave subsonic filter at 42 Hz. The "out" position removes the subsonic filter from the system.

SPS COMPRESSION ENABLE/DEFEAT (3)

SPS compression is defeated when the switch is "in". SPS should be enabled at all times to protect speakers.

SPS ACTIVE LED (4)

Illuminates when SPS compression is taking place. With the SPS switch in the "in" position, the SPS is defeated.

POWER ON LED (5)

Indicates when AC power is being supplied to the unit.

POWER SWITCH (6)

Depress to "on" position to turn on.

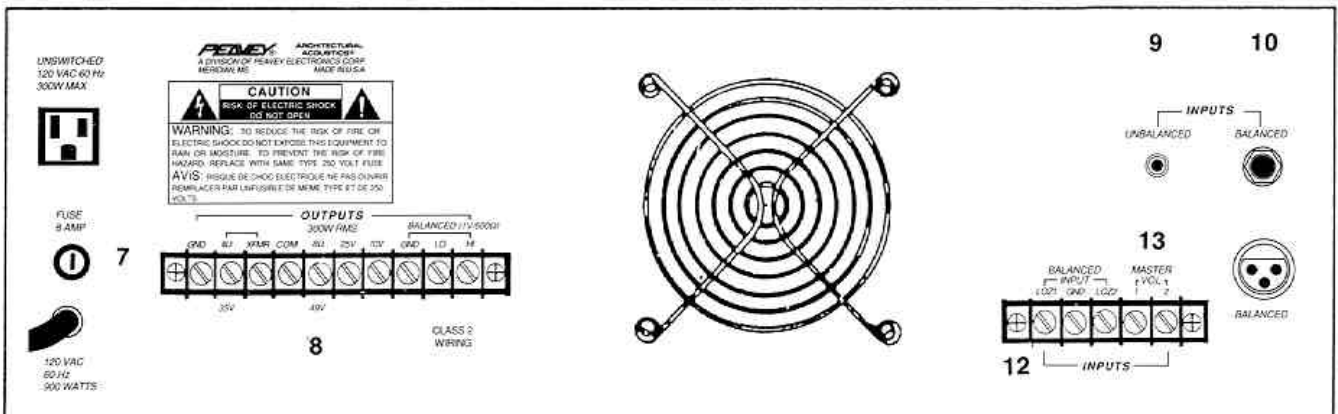

FUSE (7)



The fuse is located within the cap of the fuseholder. If the fuse should fail, IT MUST BE REPLACED WITH THE SAME TYPE AND VALUE IN ORDER TO AVOID DAMAGE TO THE EQUIPMENT AND TO PREVENT VOIDING THE WARRANTY. If the amp repeatedly blows fuses, it should be taken to a qualified service center for repair.

WARNING: THE FUSE SHOULD ONLY BE REPLACED WHEN THE POWER CORD HAS BEEN DISCONNECTED FROM ITS POWER SOURCE.

OUTPUTS (8)

A direct output, as well as several transformer outputs, are provided to allow the proper interface between the amplifier and the speaker system. The direct output allows direct connection to a 4 ohm speaker system. To use this output, disconnect the jumper between the 4 Ω terminal and the XFMR terminal. Connect the speaker (or speakers) from the COM terminal to the 4 Ω terminal. 8 ohm, 25 volt and 70 volt balanced outputs are also provided. To use these outputs, the jumper between 4 Ω and XFMR must be installed. For 8 ohm speaker systems, connect between the COM terminal and the 8 ohm terminal. 25V and 70V outputs are also provided for "constant voltage" speaker distribution systems. The 25V output connection is between the COM terminal and the 25V terminal. The 70V output connection is between the COM terminal and the 70V terminal. One more output is provided on the IPA Series amplifiers. This is a balanced, transformer isolated line level output that is provided for direct connection to "music on hold" systems, booster power amplifiers, etc. This output is designed to deliver 1V RMS into a 600 ohm load. See figures 5 through 8 for possible output connections.

RCA INPUT JACK (9)

The RCA line input is paralleled with other inputs. See figure 4 concerning use of this jack.

1/4" INPUT JACK (10)

The 1/4" phone input allows balanced operation (RTS). This jack serves as an unbalanced input when used with a "mono" (tip-sleeve) 1/4" plug.

BALANCED INPUT (XLR) (11)

The balanced input is in parallel with other inputs and allows balanced operation with XLR connection.

LINE INPUTS (12)

The input terminals are configured to allow balanced or unbalanced signals to be connected to the system. See figures 1 and 2.

EXTERNAL MASTER VOLUME (13)

These terminals allow connection of an external volume control. To gain complete control of volume from an external volume control, the front panel "level" control must be set to maximum. The external volume control should be connected as shown in figure 3.

INSTALLATION INFORMATION POWER HANDLING AND GROUNDING:

For your safety, we have incorporated a 3-wire line (mains) cable with proper grounding facilities. It is not advisable to

remove the ground pin under any circumstances. If it is necessary to use the equipment without proper grounding facilities, suitable grounding adaptors should be used. Less noise and greatly reduced shock hazard exists when the unit is operated with the proper grounded receptacles.

ARCHITECTURAL & ENGINEERING SPECIFICATIONS

The power amplifier shall have one input with provisions for balanced and unbalanced signals. Connections for the balanced input shall be provided via an (RTS) 1/4" jack, XLR "cannon" jack, and barrier strip connections. Connections for the unbalanced input shall be provided by the (RTS) 1/4" jack, barrier strip connections, and an RCA phono jack.

Provision for an external master volume control shall be made via barrier strip connections on the back panel. The unit shall be packaged in a rugged metal chassis 19" wide by 5 1/4" high by 13 1/8" deep (including external handles). The unit shall operate from standard 120 volts AC, 60 Hz power. The power amplifier shall be capable of delivering 300 watts into 4 ohms and 8 ohms, as well as providing 25 volt rated power and 70 volt line outputs. The unit shall be capable of delivering 40 Hz to 20 kHz +0/-1 dB into 4 ohms at its direct output at .1% or less distortion with system hum and noise at least 95 dB below rated output. The unit shall be called the Peavey Architectural Acoustics Division model IPA 300T.

Rated Power & Load Direct Output:

300W RMS @ 4 ohms

Transformer Output (Fully Isolated)

300W RMS @ 16 ohms (70V)/2 ohms (25V)

Distortion:

0.1% THD @ rated power

Frequency Response Direct Output:

+0/-1 dB 40 Hz to 20 kHz

Hum & Noise

Greater than 95 dB below rated power

Input Sensitivity

1.0V RMS

Subsonic Filter

Provides an 18 dB per octave roll off of low frequencies with the 3 dB point at 42 Hz

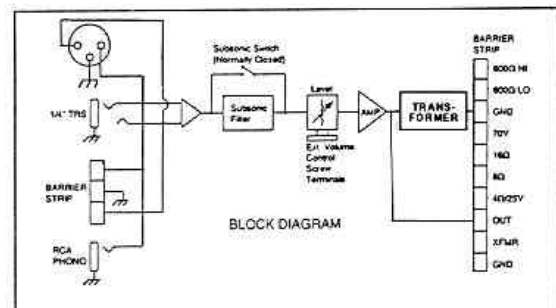

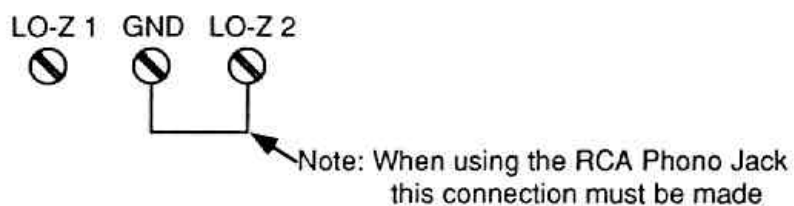
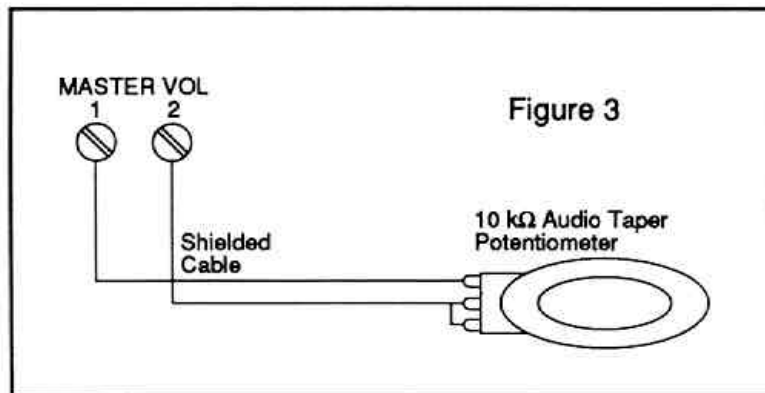
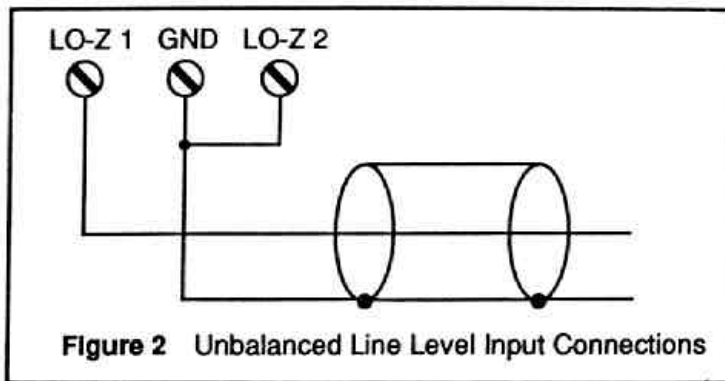
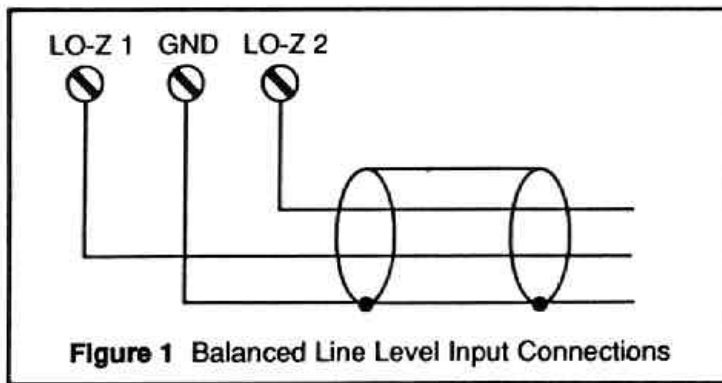

Figure 4 RCA Phono Jack Configuration of Barrier Strip

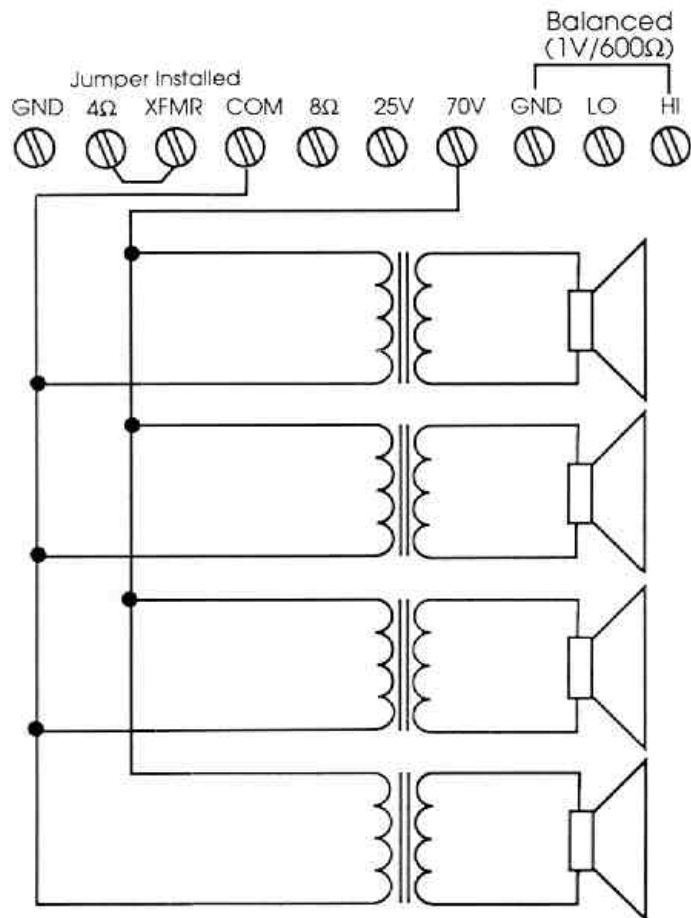

Figure 5: 70V "Constant Voltage" Distribution System

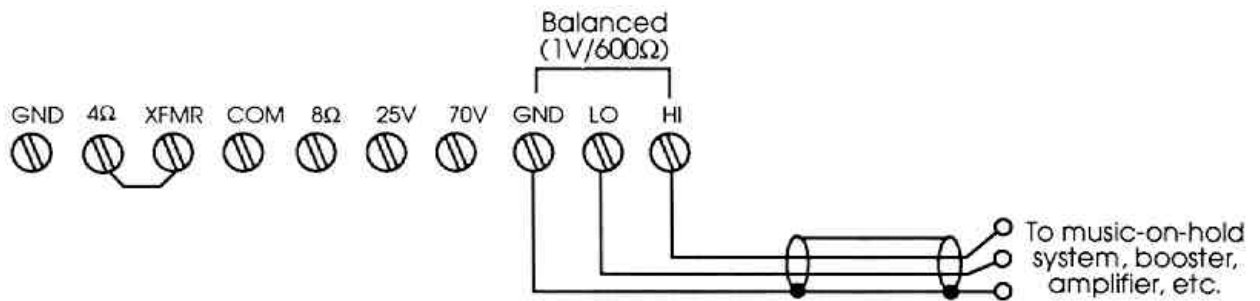
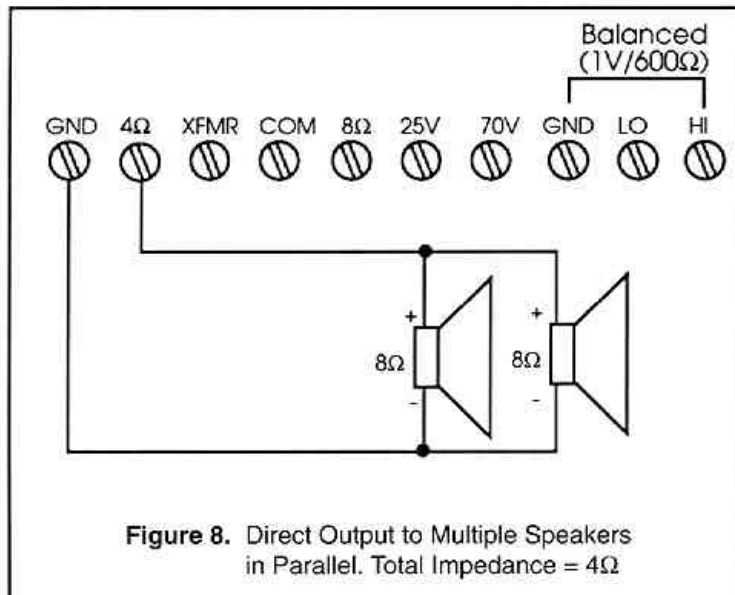
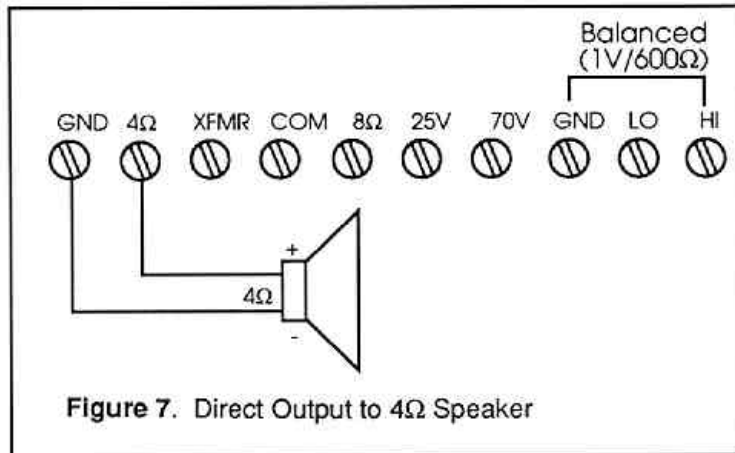

Figure 6. 600 ohm Balanced Output Connection



WARRANTY

Peavey Electronics Corporation warrants to the original purchaser of this new Architectural Acoustics™ product that it is free from defects in material and workmanship. If within one (1) year from date of purchase a properly installed product proves to be defective and Peavey is notified, Peavey will repair or replace it at no charge. (Note: Batteries and patch cords not covered.) "Original purchaser" means the customer for whom the product is originally installed. Damage resulting from improper installation, interconnection of a unit or system of another manufacturer, accident or unreasonable use, neglect or any other cause not arising from defects in material and workmanship is not covered by this warranty. The warranty is valid only as to products purchased and installed in the United States.

THIS LIMITED WARRANTY IS IN LIEU OF ANY AND ALL WARRANTIES, EXPRESSED OR IMPLIED, INCLUDING THE IMPLIED WARRANTIES OF MERCHANTABILITY AND FITNESS FOR A PARTICULAR USE. UNDER NO CIRCUMSTANCES WILL PEAVEY BE LIABLE FOR ANY LOST PROFITS, LOST SAVINGS, INCIDENTAL DAMAGES OR CONSEQUENTIAL DAMAGES ARISING OUT OF THE USE OR INABILITY TO USE THE PRODUCT, EVEN IF PEAVEY HAS BEEN ADVISED OF THE POSSIBILITY OF SUCH DAMAGE. THIS LIMITED WARRANTY IS THE ONLY EXPRESS WARRANTY ON THIS PRODUCT, AND NO OTHER STATEMENT, REPRESENTATION, WARRANTY OR AGREEMENT BY ANY PERSON SHALL BE VALID OR BINDING UPON PEAVEY.

Peavey's liability to the original purchaser for damages for any cause whatsoever and regardless of the form of action, is limited to the actual damages up to the greater of Five Hundred Dollars (\$500) or an amount equal to the purchase price of the product that caused the damage or that is the subject of or is directly related to the cause of action. This limitation of liability will not apply to claims for personal injury or damage to real property or tangible personal property allegedly caused by Peavey's negligence. For information on service under this warranty, call a Peavey customer service representative at (601) 483-5376.

IMPORTANT SAFETY INSTRUCTIONS

WARNING: When using electric products, basic cautions should always be followed, including the following:

1. Read all safety and operating instructions before using this product.
2. All safety and operating instructions should be retained for future reference.
3. Obey all cautions in the operating instructions and on the back of the unit.
4. All operating instructions should be followed.
5. This product should not be used near water, i.e., a bathtub, sink, swimming pool, wet basement, etc.
6. This product should be located so that its position does not interfere with its proper ventilation. It should not be placed flat against a wall or placed in a built-in enclosure that will impede the flow of cooling air.
7. This product should not be placed near a source of heat such as a stove, radiator, or another heat producing amplifier.
8. Connect only to a power supply of the type marked on the unit adjacent to the power supply cord.
9. Never break off the ground pin on the power supply cord. For more information on grounding, write for our free booklet "Shock Hazard and Grounding."
10. Power supply cords should always be handled carefully. Never walk or place equipment on power supply cords. Periodically check cords for cuts or signs of stress, especially at the plug and the point where the cord exits the unit.
11. The power supply cord should be unplugged when the unit is to be unused for long periods of time.
12. If this product is to be mounted in an equipment rack, rear support should be provided.
13. Metal parts can be cleaned with a damp rag. The vinyl covering used on some units can be cleaned with a damp rag or an ammonia-based household cleaner if necessary. Disconnect unit from power supply before cleaning.
14. Care should be taken so that objects do not fall and liquids are not spilled into the unit through the ventilation holes or any other openings.
15. This unit should be checked by a qualified service technician if:
 - a. The power supply cord or plug has been damaged.
 - b. Anything has fallen or been spilled into the unit.
 - c. The unit does not operate correctly.
 - d. The unit has been dropped or the enclosure damaged.
16. The user should not attempt to service this equipment. All service work should be done by a qualified service technician.
17. This product should be used only with a cart or stand that is recommended by Peavey Electronics.
18. Exposure to extremely high noise levels may cause a permanent hearing loss. Individuals vary considerably in susceptibility to noise induced hearing loss, but nearly everyone will lose some hearing if exposed to sufficiently intense noise for a sufficient time. The U.S. Government's Occupational Safety and Health Administration (OSHA) has specified the following permissible noise level exposures.

Duration Per Day In Hours	Sound Level dBA, Slow Response
8	90
6	92
4	95
3	97
2	100
1 1/2	102
1	105
1/2	110
1/4 or less	115

According to OSHA, any exposure in excess of the above permissible limits could result in some hearing loss.

Ear plugs or protectors in the ear canals or over the ears must be worn when operating this amplification system in order to prevent a permanent hearing loss if exposure is in excess of the limits as set forth above. To ensure against potentially dangerous exposure to high sound pressure levels, it is recommended that all persons exposed to equipment capable of producing high sound pressure levels such as this amplification system be protected by hearing protectors while this unit is in operation.

SAVE THESE INSTRUCTIONS!



Features and specifications subject to change without notice.

A Division of **Peavey Electronics Corporation**

711 A Street / Meridian, MS 39301 / U.S.A. / (601) 483-5376 / Fax (601) 486-1154

#80301548

